

## Type 7:

# Installation instructions, Wingrail, Quarter round duct with Fasttrack

### Installation instructions

Inspect your shipment carefully matching contents with packing slip information. Make sure everything is present. Note any missing or damaged pieces listed on the Bill of Lading before accepting the shipment in order to facilitate a claim for shipping damage.

Air Sox™ products are for use only as described in the brochure and catalogue published by Air Sox™. All other use is without liability for Air Sox™. If you have any questions about Air Sox™ products please contact your local Air Sox™ office.

### Special tips:

1. All duct components are given a position number which can be found on the washing label (washing label is sewn onto the inside of the duct, one present at all joints). **When mounting, always connect continuous numbers, example: Pos. 1.1 => Pos. 1.2 => Pos. 1.2 => Pos. 1.3 (by identical pieces, the components are given the same position number).**
2. To hide the clamp you can wrap the collar piece over the clamp
3. When the unit is turned on, gently pull the duct on one end to straighten out any wrinkles, and fix the clip at the end of the duct to the suspension wire, using the included wire locknut.

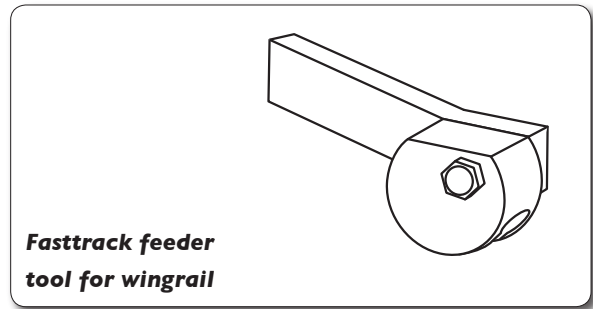
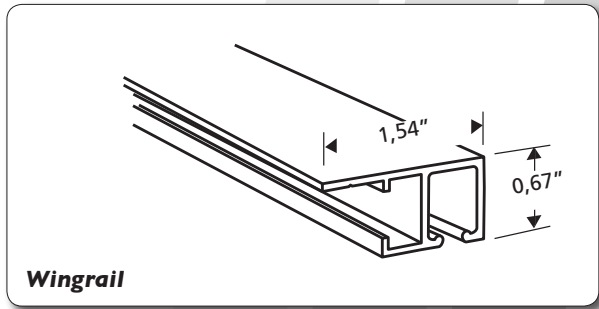
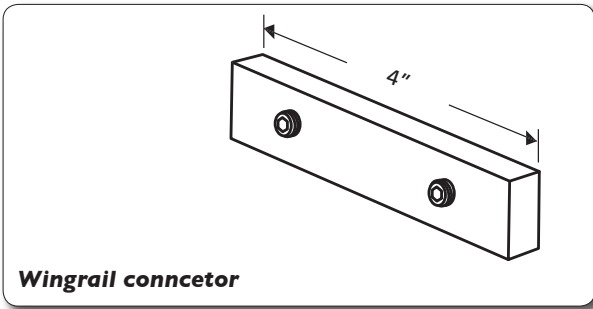
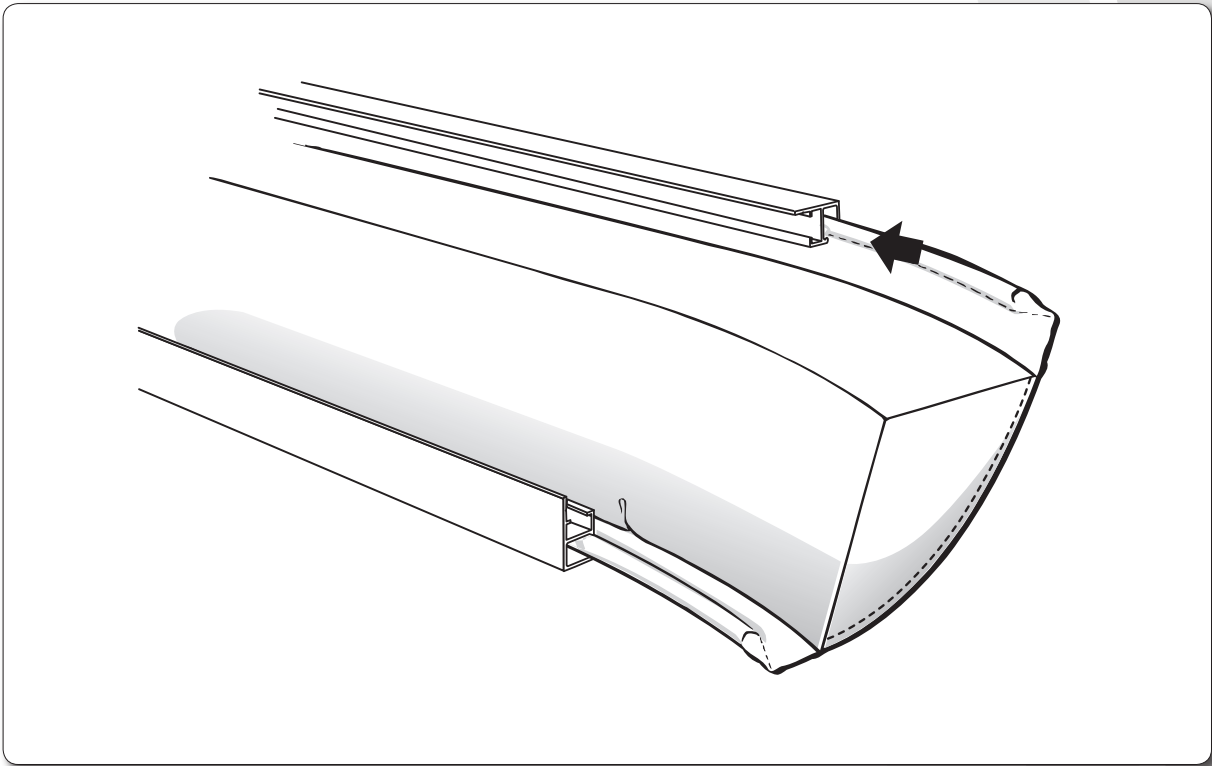

## 1. Installing quarter round ducts with Fasttrack into Wingrail

- Attach runs of Wingrail to ceiling/wall using screw every 1 to 3 foot depending on type of ceiling/wall and size of duct. Please note, the wing on the rail has a groove for lining up when drilling the holes needed in the rail. Important note: The distance from rail to corner must be the same as the radius of the duct, example: a Q24" duct has a radius of 12", so must have rails fitted with distance 12" center of rail to corner ceiling/wall.
  - Sections of Wingrail is joined by sliding a Wingrail connector into the side groove of the rail, and then tightening the allen screws. When tightening the allen screws, the 2 rail sections will self-align.
- \*Slide duct onto the Wingrail to fully extended position.
  - Fix duct to steel duct/fan by means of clamp.
- \*If you have ordered our special Fasttrack feeder for Wingrail, this is inserted in the side groove of the rail, prior to sliding duct onto track. This will greatly increase the speed with which an duct can be mounted.



# Washing instructions

## Cleaning of polyester and Trevira CS

Wash 2-4 times at max 104°F with washing powder in accordance to instructions by manufacturer.

If ducts are heavily soiled, they should be rinsed between washes. If the ducts are to be disinfected, add up to 7 oz of active chlorine to the final rinse water (N.B. colored socks can loose some of their color when disinfected)

Rinse ducts in clean cold water.

Socks can be spin dried, the exception being ducts with internal rings. Here the rings must removed prior to drying.

## Chemical cleaning of polyester and Trevira CS

Chemical cleaning of ducts should only be attempted in cases where the ducts are slightly dirty. To achieve some degree of disinfection, it is recommend to use chemical cleaning with perchlorethylen.

## Washing or chemical cleaning, clean room materials

Washing or chemical cleaning of clean room materials is not recommend under normal circumstances, but is possible following the procedures given for Polyester and Trevira CS material. If the fabric turns slightly grey during operation, the pre-filtration should be examined and possibly exchanged for a filter better suited. During the washing procedure, particles can be picked up by the fabric and later blown into the room. If the clean room socks are being washed there is no further guarantee for the function of the socks from Air Sox™, with regards to particle count.

## Cleaning of Inject ducts

Air Sox™ Inject ducts do not require cleaning from a flow technical point of view, however aesthetics or hygiene conditions may necessitate the cleaning of the ducts. Air Sox™ Inject systems can be cleaned manually on the outside and on the inside. For this purpose a thin water/soap dilution and a brush or a sponge should be used (standard grade washing detergent can be used). After the cleaning the Inject Socks should be rinsed with clean water. If the Inject Sock is very dirty the inside of the sock should be turned out and swept or vacuumed. Use of Hydrocarbon based solvents can cause damage. Under no circumstances use solvents containing Chlorate, this will deteriorate the PVC coating, causing the material to turn brittle, eventually cracking can occur.

## Cleaning of M0 Ducts (Glass fibre weave)

These ducts must only be cleaned by means of a damp cloth. A standard commercial grade detergent can be used in a watery solution for this purpose. Ducts must be allowed to drip dry.



MI510007

